

Aspiring always to be an environmentally friendly and trustworthy company

TAMAGAWA NEWS

2020.3
Vol. 24



NEW! TBL-i⁶ series AC Servo Motor / 25bits Rotary Encoder

Explore the Area
S-BIRD

Minoru Takahashi

New small and low inertial AC servo motor with high resolution 25bits absolute encoders are become available now!

NEW

AC Servo Motor TBL-i6 Series



Small size

Compact compared to the existing series and achieving miniaturization of equipment



Low cogging , Low vibration

Low vibration realized by optimization of magnetic design



Low Inertia

Rotor inertia is lower and high frequency operation is more prompt.



Can be equipped with silent brake

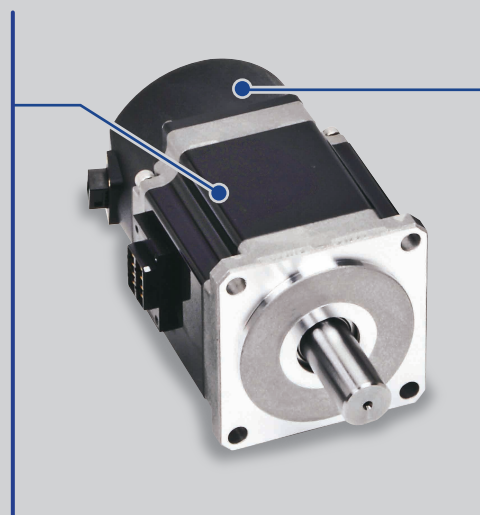

25
bits

Equipped with 25bits standard absolute encoder

25-bit battery-less encoder:
Option High-reliability resolver is available to mount

Specifications

Motor Flange Size	Power Supply Voltage	Model	Rated Output	Torque		Rated Amature Current of E.D.C.M.	Peak Amature Current of E.D.C.M.	Rotation Speed		Rotor Inertia	
				Rated Torque	Momentary Max. Torque			Rated	Max.	No Brake	With Brake
[mm]	[V]		[W]	[N·m]	[N·m]	[A (rms)]	[A (rms)]	[min ⁻¹]	[min ⁻¹]	[10 ⁻⁴ kg·m ²]	
□40	AC200	TSM4154	100	0.318	1.11	0.8	2.6	3,000	6,000	0.028	0.041
□60	AC200	TSM4252	200	0.64	2.24	1.5	4.9	3,000	6,000	0.11	0.21
		TSM4254	400	1.27	4.46	2.1	7.1	3,000	6,000	0.20	0.35
□80	AC200	TSM4354	750	2.39	8.36	4.1	14.1	3,000	6,000	0.74	1.06

※Combination with our driver.

New products

Outline

The outline is a 23 bits absolute encoder type.
(unit: mm)

40mm

TSM4154 (No Brake Type)

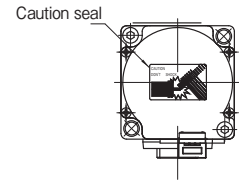
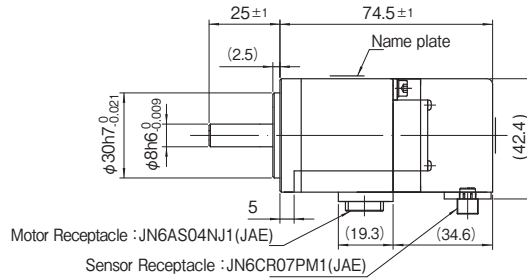
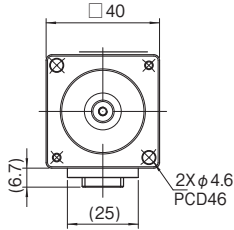

60mm

TSM4252 (No Brake Type)
TSM4254 (No Brake Type)

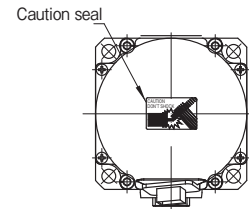
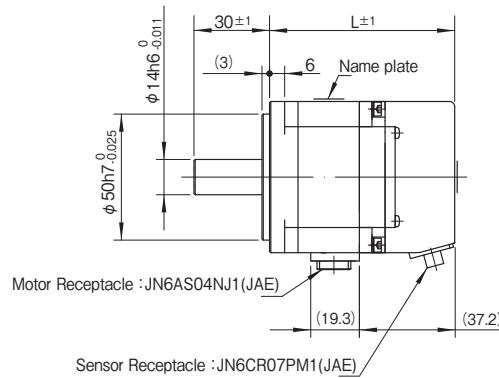
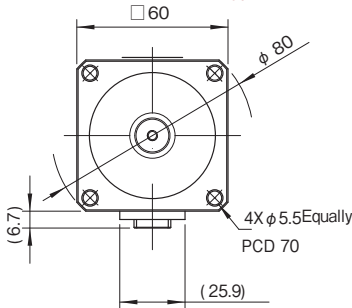

Rated Output	200W	400W
Model	TSM4252	TSM4254
L (mm)	75 ± 1	91 ± 1

80mm

TSM4354 (No Brake Type)

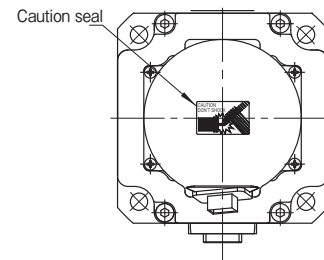
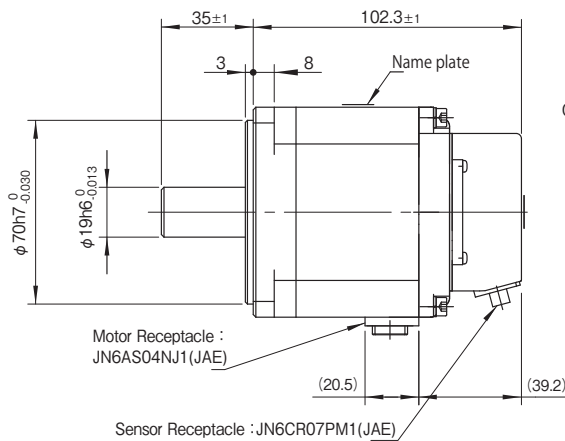
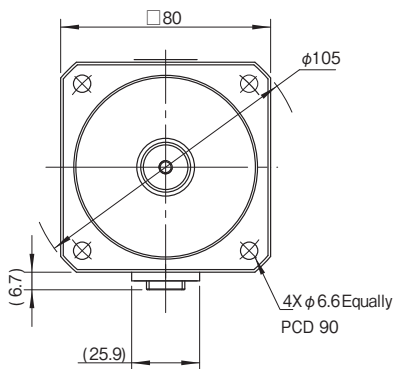

Applications

Chip Mounter

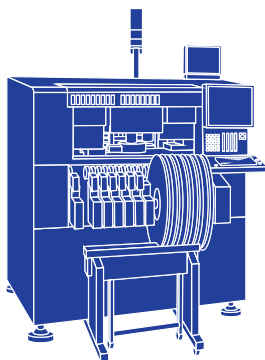

Pick-up Robot

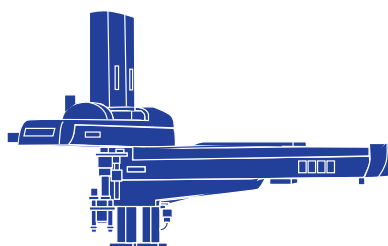

Packaging Machine

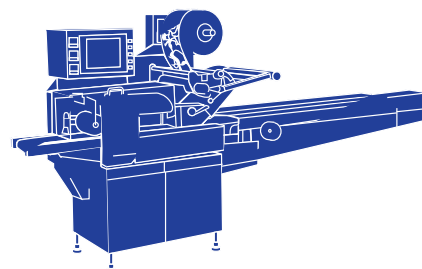



High Resolution 25bits Rotary Encoder

New products



Φ48mm Type
TS5720N8410



Φ35mm Type
TS5722N10

High resolution of 25bits per rotation

Capable of advanced position/speed control with 25 bits resolution (approx. 33,000,000 division)

High robustness

High noise resistance by using feedback system in interpolation circuit

Operating/Storage temperature range: Up to 105°C

Usable in higher temperature compared to conventional models (~85°C)

Energy saving

Power consumption is drastically reduced compared to conventional models

Electrical Spec.

Model No.	TS5720N8410 TS5722N10	
Single-turn	25bit	
Multi-turn	16bit	
Output phase	Pure binary code	
Supply voltage	DC+5V±5%	
Consumption current	Nomal operation	50mA TYP.
	Battery operation	30μA TYP.
Output form	Line driver	
Maximum allowable rotation	8,500min ⁻¹	
Serial data transfer cycle	35μsec~63μsec	
Data code	Bace band NRZ	

Mechanical Spec.

Model No.	TS5720N8410	TS5722N10
Starting torque (at 20°C)	9.8×10 ⁻³ N·m Max	6.5×10 ⁻³ N·m Max
Moment or inertia	6.5×10 ⁻⁶ kg·m ² TYP.	1.0×10 ⁻⁶ kg·m ² TYP.
Maximum allowable rotation	6,000min ⁻¹	
Maximum angler acceleration	80,000rad/sec ²	
Mass	0.3kg Max	0.06kg Max

Environment

Model No.	TS5720N8410	TS5722N10
Protective structure	IP40	Not enclosed
Operating Temp. range	-10~+105°C	
Strage Temp. range	-20~+105°C	
Humidity	90%RH Max	
Shock	1,960m/s ² , 11msec	
Vibration	1.5mm, 5~58Hz 98m/s ² , 58~2,000Hz	

(Foundation) Minami-Shinshu Iida Industry Center **Industrial Technology Test and Research Laboratory**

The Industrial Technology Test and Research Laboratory of the Minami-Shinshu Iida Industry Center within S-BIRD is Japan's first environmental testing center for aircraft equipment. The development and operation plan was reviewed by the "Working Group to Review Issues Related to Infrastructure Development such as Environmental Testing", which is participated in by the national government, local governments, and companies, etc. This leads to several test systems being introduced, becoming the first of their kind in Japan. Tamagawa Seiki is also heavily involved as a member of the aforementioned working group.

Explosion-proof test evaluation system

Testing flammability of fuel tank peripheral equipment

This system, which was introduced in FY 2017, tests whether equipment around the fuel tank will ignite or explode in the event it is exposed to fuel in an airborne aircraft. The main subjects of the test are sensors and actuators that are often installed around the tank.

The first test system of its kind in Japan

This test system is the first of its kind in Japan to comply with the U.S. commercial aircraft equipment standard (RTCA-DO160G Sec. 24), and the first in the world to be able to automatically control all processes.

It is also capable of supporting the MIL (MIL-STD-810) test, which is the U.S. military standard for the procurement of supplies. As MIL is widely used as a standard for consumer products, it can be applied to product testing in various fields, not only those related to aerospace.

Test procedure

The test product is placed in a cylindrical chamber with an inner diameter of 1.5 m and a depth of 2.0 m, and a simulated aviation fuel (normal hexane) is sprayed while changing the air pressure and temperature in a sealed state. While recording the test with a high-speed camera, a visual observation can also be made from a tempered glass window. The manipulator can also be used to manipulate test specimens.



The weight of the system's main unit is about 10 tones.

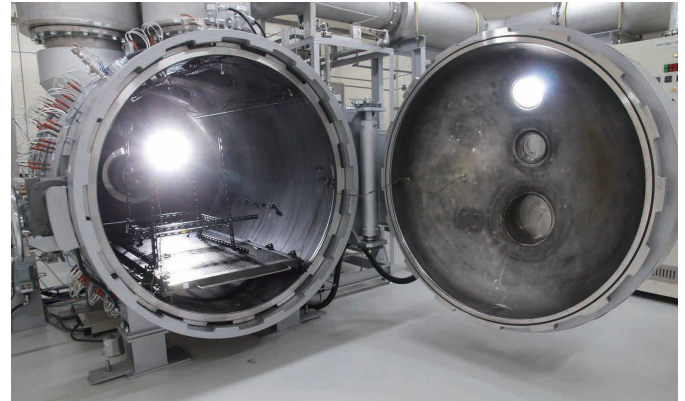

A view with the clutch door open. The explosion-proof test evaluation system is like a huge pressure cooker.



View from inside the tank where lighting, cameras, fuel spray nozzles, sensors, and so forth were installed.



The operation panel enables manual operation as well as program operation in accordance with the standard.

Replicates altitudes up to 30,000m

The testable pressure range is 101.3 kPa to 4 kPa, which replicates an environment equivalent to an altitude of 100,000 ft (30,480 m), the level at which satellites orbit. The temperature range is 10 °C to 260 °C, and a rapid change from room temperature to 150 °C within 90 minutes can be replicated by the system. All of these operations can be set automatically.

Consideration is also given to the environment

Consideration is given to the location of S-BIRD near residential areas by equipping the test system with a large silencer that reduces the noise of the explosion to less than 65 dB and automatic processing equipment that decomposes unburned gas to make it harmless.

Development and manufacturing by local company

Design and manufacturing were outsourced to Hanyuda Co., Ltd. in Nagano City, and were developed under the supervision of a quality inspector commissioned by the FAA (U.S. Federal Aviation Administration). Hanyuda is a long-established pressure vessel manufacturer specializing in the manufacturing of high pressure mushroom sterilizers. In formulating specifications, Tamagawa Seiki also gave advice as a member of the working group.



A huge silencer at the top catches the eye. The sub-chamber is on the left.



The combustion of the fuel used in the experiment is checked in the sub-chamber.

Information

01

Notice of Opening Nishi-Kanto Office

Our Hachioji Office and Kanagawa Office merged to form the newly opened Nishi-Kanto Office.

The Nishi-Kanto Office is located in Sagami-hara City in Kanagawa Prefecture, and is a conveniently located office, 3 minutes' walk from Fuchinobe Station on the JR Yokohama Line. Nearby is JAXA Sagami-hara Campus, and when you get off the train at Fuchinobe Station, the first thing you will see is a sign for the asteroid explorer "Hayabusa". Sagami-hara City is home to Sagami-hara Campus of Aoyama Gakuin University, which won the 2020 Hakone Ekiden. It is a city with a large student population.

When the long-awaited Linear Chuo Shinkansen commences its service in 2027, the nearest stop on route "Hashimoto Station" can be reached in about 10 minutes. There is great anticipation for the day it becomes a place in which one can move to the Iida region in less than an hour.

Our new office has a total of 16 staff members, and is in charge of our power product business in Tokyo, Kanagawa, Yamanashi, Shizuoka, and Nagano. Although the staff's range of responsibilities has increased, the experience of our veteran staff and the vitality of our young blood have created a new sales style, providing satisfaction to customers, and working hard as a united team to become an office with a strong presence.

We encourage you all to come and visit us at our Nishi-Kanto Office when you are in the Kanto area.



Information

02

Notice of Change to Laboratory Names

The names of Tamagawa Seiki's laboratories have been changed as follows since November 21 of last year.

After	Before
<p>Sensortronics Laboratory Product group: Rotary encoders, Resolvers, Railway sensors, etc. Location: Second Plant</p>	<p>Motortronics Laboratory</p>
<p>Motortronics Laboratory Product group: Servo motors, Servo drivers, MEMS gyros, etc. Location: Second Fukuchi Factory, Second Hachinohe Factory, Second Plant</p>	<p>Motion Control Laboratory</p>

Information

03

Winner of New Product Development Award from ABB Headquarters

On November 28, 2019, Supplier Day was held in grand fashion at ABB's headquarters with 300 people in attendance.

The Tamagawa Seiki Group was awarded the honor of receiving the illustrious "New Product Development Award". This award is given to suppliers who have made a dedicated contribution to new development projects, with only the Tamagawa Seiki Group selected for this honor.

At present, three next-generation robot projects are in progress with ABB's headquarters. As well as the cooperative robot project, it is anticipated that our motors will be used for the renewal of small, medium, and large robots. The technical demands are high in each project, and it was thanks to the long-term support from those involved in each of our divisions that led to receiving the award.

While we were able to receive this wonderful award on this occasion, it is linked to the warm and patient support that our customers have given us. We will continue to march on day by day to be able to gain even greater level of trust from our customers.



Information

04

Information on Exhibitions

Small Satellite Conference 2019

Sat. August 3 to Thu. August 8

At an international conference on small satellites held at Utah State University in the United States, we exhibited reaction wheels, fiber optical gyros (FOG) and inertial reference units (IRU), step motors, and resolvers and so forth that are operating in space.

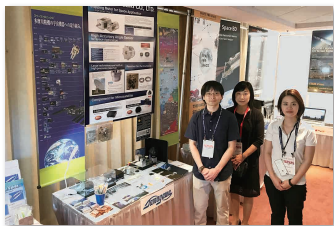

DSEI JAPAN '19

Mon. November 18 to Wed. November 20

Japan's first comprehensive defense and security related exhibition was held at Makuhari Messe.

We exhibited aircraft, space, and defense-related products, as well as surveillance camera systems and gyros.

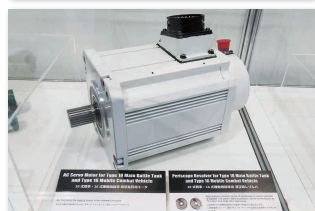

International Robot Exhibition 2019

Wed. December 18 to Sat. December 21

Our new products, the TBL-i6 Series AC Servo Motor and a 25bits Rotary Encoder, as well as a Torque Servo Module show model were exhibited at the exhibition, receiving reviews from many visitors.



The cover of this edition



Automation Clock “Hachinohe”

Made by Mr. Minoru Takahashi
Automation clock “Hachinohe” is placed in Hachinohe Portal Museum “hacchi”. Eight dolls in the motif of Hachinohe’s specialties such as sea cat, squid and Senbei-jiru move to the music at certain time. It is a work that represents the character of Hachinohe from a warmer feel of wood and technique to move charming dolls and gear wheels delicately.

TAMAGAWA SEIKI CO., LTD.

Headquarters & First Plant:
1879 Ohyasumi, Iida, Nagano Pref. 395-8515 Japan
PHONE: +81-265-21-1800
FAX: +81-265-21-1861

Tokyo Office:
3-19-9 Shinkamata, Ohta-ku, Tokyo 144-0054 Japan
PHONE: +81-3-3738-3133
FAX: +81-3-3738-3134

TAMAGAWA TRADING CO., LTD.

Headquarters:
1-3-1 Haba-cho, Iida, Nagano Pref. 395-0063 Japan
PHONE: +81-265-56-5423
FAX: +81-265-56-5427



Nieuwland Parc 13i
2952 DA Alblasterdam
The Netherlands

T +31(0)78-6215900
F +31(0)78-6215815
info@ave-nl.com
www.ave-nl.com

Motortronics®

URL <https://www.tamagawa-seiki.com>

